

2.4 Fittings inyectados para electrofusión

Copla EF PE 100 PN 16 (SDR 11)

dn	dimensiones					PN-S	peso
	d _e	LZ	f	a			
20	33	33	15	13	70	PN 25 - S5	45
25	38	33	15	12	70	PN 25 - S5	55
32	46	38	19	12	80	PN 25 - S5	75
40	56	44	22	13	90	PN 25 - S5	110
50	68	49	23	14	100	PN 25 - S5	155
63	82	54	26	18	111	PN 25 - S5	225
75	99	60	36	14	120	PN 25 - S5	330
90	116	65	37	14	130	PN 25 - S5	490
110	145	70	36	18	140	PN 25 - S5	800
125	163	76	39	18	151	PN 25 - S5	1060
140	183	81	48	18	161	PN 25 - S5	1440
160	207	86	53	20	172	PN 25 - S5	1950
180	228	97	56	23	193	PN 25 ★-S 5	2550
200	252	101	65	22	203	PN 25 ★-S 5	3440
225	276	112	67	22	223	PN 25 ★-S 5	4190
250	312	122	60	32	244	PN 25 ★-S 5	5900
280	341	133	55	38	265	PN 20 ★-S 5	7100
315	392	142	70	37	284	PN 25 ★-S 5	10750
355	430	156	60	45	312	PN 20 ★-S 5	11750
400	461	170	60	41	340	PN 20 ★-S 5	14150

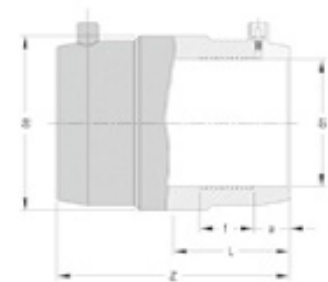

dn	dimensiones					PN-S	peso
	d _e	LZ	f	a			
450	527	175	68	45	350	PN 12,5-S6, 3	18000
500	585	179	87	36	359	PN 12,5-S6, 3	23500
560							
630							

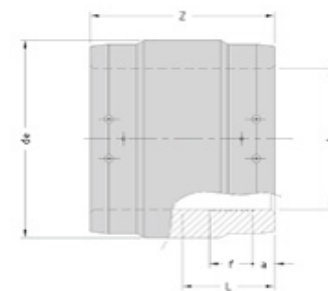

Fittings inyectados para electrofusión 2.4

Codo 90° EF PE 100 PN 16 (SDR 11)

dn	dimensiones					PN-S	peso
	d _e	LZ	f	a	PE- 100		
25	38	33	15	9	57	PN 25 - S5	80
32	46	39	18	10	75	PN 25 - S5	130
40	56	48	25	11	80	PN 25 - S5	190
50	68	54	27	12	89	PN 25 - S5	300
63	83	52	27	13	104	PN 25 - S5	450
75	97	64	29	18	116	PN 25 - S5	665
90	116	70	37	18	130	PN 25 - S5	1040
110	142	76	39	20	146	PN 25 - S5	1615
125	162	79	42	19	152	PN 16 - S5	2130
140	174	85	38	20	166	PN 16 - S5	2520
160	206	89	45	20	180	PN 16 - S5	4050
180	226	116	50	23	215	PN 16 - S5	4900
200	251	118	55	23	229	PN 16 - S5	6450

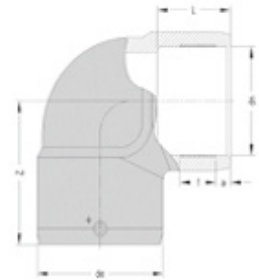

Codo 45° EF PE 100 PN 16 (SDR 11)

dn	dimensiones					PN-S	peso
	d _e	LZ	f	a	PE- 100		
32	46	39	18	10	57	PN 25 - S5	110
40	56	48	25	11	70	PN 25 - S5	175
50	68	54	27	12	75	PN 25 - S5	260
63	82	52	27	13	86	PN 25 - S5	390
75	97	64	29	18	98	PN 25 - S5	610
90	116	70	37	18	110	PN 25 - S5	905
110	142	76	39	20	114	PN 25 - S5	1415
125	162	79	42	19	119	PN 16 - S5	1830
160	206	89	45	20	134	PN 16 - S5	3400
180	226	105	50	23	162	PN 16 - S5	
200	251	112	55	23	175	PN 16 - S5	

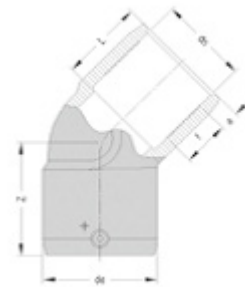

2.4 Fittings inyectados para electrofusión

Tee 90° EF PE 100 PN 16 (SDR 11)

dn	dn ₁	dimensiones							peso	
		d _e	Lh	f	a	Z	Z ₁	PE-100	PN16-S5	
25	25	39	33	15	11	60	53	111	95	
32	32	44	44	28	10	48	64	94	105	
40	40	54	49	37	11	57	73	112	175	
50	50	66	55	36	12	62	81	128	300	
63	63	81	61	32	13	72	94	153	420	
75	75	96	64	29	18	75	113	176	700	
90	90	116	70	37	18	85	125	202	1170	
110	110	141	76	39	20	84	141	233	1725	
125	125	161	79	42	10	100	156	269	2800	
140	140	174	85	38	20	121	150	308	3050	
160	160	206	89	51	20	127	184	350	5570	
180	180	227	105	48	23	130	188	368	6340	
200	200	252	112	55	23	135	205	400	8230	

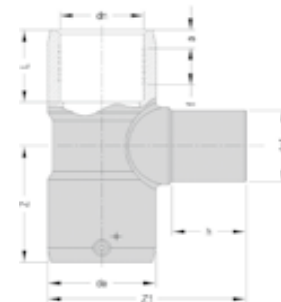

Cap end EF PE 100 PN 16 (SDR 11)

dn	dimensiones			peso	
	f	L	Z	PE-100	
				PN 16 - S5	PN 25 - S5
20	26	33	100	60	60
25	30	33	104	70	75
32	22	38	98	92	100
40	24	44	114	135	155
50	24	49	127	195	250
63	26	54	136	310	360
75	44	44	164	410	550
90	34	70	164	630	850
110	47	68	187	990	1400
125	47	76	198	1405	1800
140	45	85	207	1870	2400
160	40	92	211	2405	3300

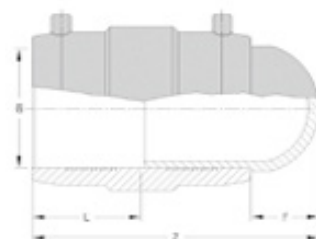

Fittings inyectados para electrofusión 2.4

Reducción concéntrica EF PE 100 PN 16 (SDR 11)

dn	dn ₁	dimensiones									peso
		d _e	d _{e1}	L	L ₁	f	f ₁	a	a ₁	Z	PE-100
											PN16-S5
32x	20	44	32	46	38	34	22	10	10	105	75
32x	25	45	36	44	45	31	21	10	10	103	75
40x	20	55	33	49	39	27	22	11	10	120	105
40x	25	55	36	48	40	27	21	11	10	114	100
40x	32	55	44	54	50	30	29	11	10	109	100
50x	25	67	37	49	40	27	21	12	10	126	140
50x	32	66	44	53	49	30	29	12	10	121	170
50x	40	66	54	55	54	33	33	12	11	119	200
63x	32	81	46	62	44	31	24	15	12	156	245
63x	40	81	54	63	54	29	20	15	13	137	250
63x	50	81	66	62	54	26	23	16	16	131	250
75x	63	97	81	75	62	34	33	13	13	160	395
90x	50	117	66	79	55	45	25	18	16	185	555
90x	63	115	81	77	62	45	33	15	13	160	515
90x	75	115	97	81	60	39	30	18	18	159	550
110x	63	144	83	79	63	40	33	20	15	201	905
110x	90	141	115	87	77	41	39	19	18	181	860
125x	90	162	118	78	68	42	34	22	17	177	1100
125x	110	162	144	79	73	33	36	22	20	164	1225
160x	90	209	119	90	79	50	50	23	17	233	2130
160x	110	208	144	95	82	48	37	25	20	218	2400
160x	125	208	162	98	87	47	30	26	21	208	2505



2.3 Fittings inyectados para termofusión

Codo 90° TF PE 100

dn	dimensiones		pesos		
			PE 100		
			SDR 17-58 PN 10	SDR 11-55 PN 16	SDR 7,4 PN 25
20	49	75		28	
25	53	80		37	
32	59	89		53	65
40	59	85		75	100
50	60	89		120	175
63	68	103		225	295
75	71	114		330	450
90	80	130	390	535	750
110	85	146	620	850	1250
125	89	159	915	1310	1800
140	94	172	1250	1795	2500
160	115	225	2155	3000	4100
180	121	235	2675	3985	
200	127	252	3335	5050	
225	138	274	5600	7620	
250	143	300	7400	10350	
280			12100	18600	
315	180	392	14550	20300	

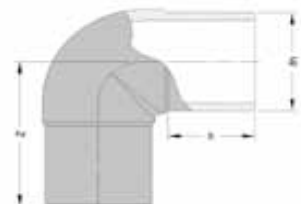

Codo 45° TF PE 100

dn	dimensiones		pesos		
			PE 100		
			SDR 17-58 PN 10	SDR 11-55 PN 16	SDR 7,4 PN 25
32	50	64		40	50
40	59	71		62	100
50	60	74		102	150
63	68	85		185	255
75	73	92		280	400
90	83	106	340	465	640
110	84	112	495	705	1000
125	89	125	740	1040	1500
140	95	128	870	1375	1950
160	100	142	1365	1990	2800
180	125	183	2300	3355	
200	131	197	3070	4385	
225	134	213	4360	6110	
250	142	232	5750	8140	
280			8200	12600	
315	210	318	11980	17000	

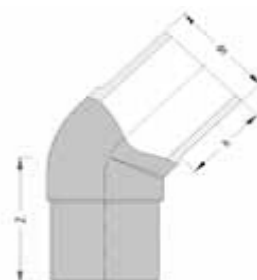

Tee 90° TF PE 100

dimensiones			pesos PE 100		
dn	h	Z	SDR 17-58	SDR 11-55	SDR 7,4
			PN 10	PN 16	PN 25
20	59	80		45	
25	60	76		50	
32	60	82		85	100
40	59	84		105	150
50	60	89		165	245
63	67	103		310	455
75	74	126		540	750
90	80	135	580	850	1170
110	95	162	965	1480	2115
125	90	160	1315	1895	2650
140	95	174	1790	2555	3500
160	106	200	2630	3765	5150
180	124	243	4140	5840	
200	130	259	5150	7485	
225	136	282	7250	9700	
250	142	307	10080	13870	
280					
315	178	388	19800	27650	



Tee reducida 90° TF PE 100

dn	dn ₁	dimensiones			pesos PE 100	
		h	h ₁	Z	SDR 17-58	SDR 11-55
					PN 10	PN 16
90	63	90	74	147		830
110	63	88	62	158		1330
110	90	95	69	162		1375
125	90	100	85	179		1790
125	110	100	95	179		1920
160	90	111	84	212	2850	3540
160	110	111	93	212	2960	3680



2.3 Fittings inyectados para termofusión

Stub end TF PE 100

dn	dimensiones										pesos			
	h			h ₁			ZC			d ₁	PE 100			
	SDR 17	SDR 11	SDR 7,4S	DR 17S	DR 11S	DR 7,4	SDR 17	SDR 11	SDR 7,4		SDR 17-S 8 PN 10P	SDR 11-S55 N 16	DR 7,4 PN 25	
20			45			7			67	27	45		25	
25		48	50		9	10		75	75	33	58		40	35
32		68	69		10	11		96	95	40	68		60	50
40	63	62	69	11	11	12	87	87	94	50	78	70	80	100
50	62	61	66	12	12	13	88	95	94	61	88	95	90	150
63	66	64	65	14	14	16	98	99	96	75	102	145	180	245
75	74	71	68	16	16	18	116	111	109	89	122	250	285	365
90	80	82	81	17	17	20	117	117	121	105	138	350	405	570
110	84	83	87	18	18	21	127	124	128	125	158	485	610	875
125	93	105	107	18	25	28	131	158	161	132	158	505	820	1225
140	104	108	105	18	25	29	154	156	159	155	187	750	1140	1650
160	109	106	104	18	30	29	156	159	160	175	212	1035	1520	2060
180	118	145	114	20	30	36	169	196	175	180	212	1140	1920	2400
200	116	112	112	24	32	36	181	182	188	232	268	2120	3000	3830
225	125	152		24	32		190	219		235	268	2130	3625	
250	134	133		25	35		205	205		285	320	3370	4695	
280	155	166		26	36		221	235		291	320	3680	5650	
315	202	205		25	35		267	275		335	370	5300	9200	
355														
400	230	230		38	48		308	310		427	482	10200	15150	

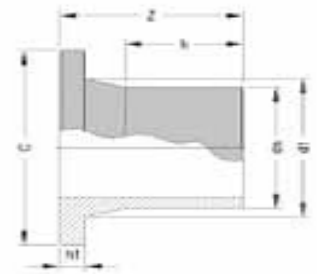

Cap end TF PE 100

dn	dimensiones		pesos		
	h	Z	PE 100		
			SDR 17-S 8 PN 10	SDR 11-S5 PN 16	SDR 7,4 PN 25
20	54	59			10
25	60	68		15	17
32	53	59		20	25
40	57	68	25	30	40
50	61	74	50	50	70
63	64	80	65	85	115
75	74	89	90	150	200
90	82	100	165	230	340
110	91	118	265	395	600
125	102	122	350	570	790
140	103	125	450	780	1150
160	101	134	665	950	1420
180	114	150	970	1450	
200	119	163	1310	1890	
225	124	180	1740	2660	
250	132	179	2275	3355	
280					
315	175	298	5060	7540	

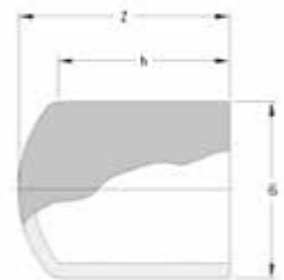

Reducción concéntrica TF PE 100

dn	dn ₁	dimensiones			pesos PE 100		
		h	h ₁	Z	SDR 17-S 8	SDR 11-S5	SDR 7,4
					PN 10	PN 16	PN 25
25x	20	49	50	18		25	25
32x	20	55	52	124		30	
x	25	61	59	130		35	35
40x	20	50	52	130		40	
x	25	59	54	128		45	
x	32	61	48	125	40	45	70
50x	25	60	50	135		60	80
x	32	60	47	134		65	90
x	40	60	62	134	50	75	110
63x	25	64	57	140		90	
x	32	64	63	143	70	100	130
x	40	68	52	139	80	105	150
x	50	63	57	132	80	115	150
75x	40	72	60	147	100	160	230
x	50	72	59	153	110	165	240
x	63	73	67	154	150	195	280
90x	50	82	61	162	180	260	345
x	63	80	68	169	190	280	400
x	75	83	71	164	205	305	445
110x	50	88	57	177	270	390	
x	63	87	69	188	285	410	555
x	75	85	72	173	285	425	620
x	90	86	81	181	330	485	690
125x	63	96	68	199		580	
x	75	95	78	191	400	610	790
x	90	96	81	191	430	625	855
x	110	96	84	192	460	720	985

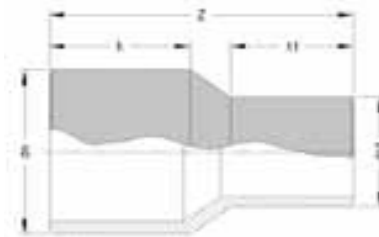

dn	dn ₁	dimensiones			pesos PE 100		
		h	h ₁	Z	SDR 17-S 8	SDR 11-S5	SDR 7,4
					PN 10	PN 16	PN 25
140x	90	95	80	205	555	815	1145
x	110	94	83	193	560	820	1215
x	125	95	89	198	590	970	1380
160x	90	101	82	221	705	1105	
x	110	101	103	270	950		
x	110	101	86	218		1160	1565
x	125	101	91	208	735	1155	1645
x	140	101	92	206	835	1235	1780
180x	125	107	88	220	1040	1515	
x	140	105	96	221	1050	1610	
x	160	107	101	224	1165	1725	
200x	140	115	95	231	1330	1950	
x	160	115	101	252	1430	2200	
x	180	117	109	236	1200	2300	
225x	90	121	89	298	1800		
x	125	131	100	288	1900		
x	160	133	120	292	2040	3085	
x	180	132	125	285	2100	3010	
x	200	132	130	277	2380	3465	
250x	180	138	124	304	2700	3950	
x	200	140	130	301	2750	4420	
x	225	137	134	296	2855	4150	

dn	dn ₁	dimensiones			pesos PE 100	
		h	h ₁	Z	SDR 17-S 8	SDR 11-S5
					PN 10	PN 16
280x	200					
x	225					
x	250					
315x	225	173	138	389	5450	8070
x	250	173	150	381	5500	7600
x	280					
355x	225					
x	250					
x	280					
x	315					
400x	280					
x	315					
x	355					

ELBOW

PN 16



ITEM CODE	METRIC mm
105/0020	20
105/0025	25
105/0032	32
105/0040	40
105/0050	50
105/0063	63
105/0075	75
105/0090	90
105/0110	110

ELBOW MALE

PN 16



ITEM CODE	METRIC mm x BSP	ITEM CODE	METRIC mm x BSP
106/0020x0015	20 x 1/2"	106/0050x0032	50 x 1 1/4"
106/0020x0020	20 x 3/4"	106/0050x0040	50 x 1 1/2"
106/0025x0015	25 x 1/2"	106/0050x0050	50 x 2"
106/0025x0020	25 x 3/4"	106/0063x0040	63 x 1 1/2"
106/0025x0025	25 x 1"	106/0063x0050	63 x 2"
106/0032x0015	32 x 1/2"	106/0063x0065	63 x 2 1/2"
106/0032x0020	32 x 3/4"	106/0075x0065	75 x 2 1/2"
106/0032x0025	32 x 1"	106/0075x0080	75 x 3"
106/0032x0032	32 x 1 1/4"	106/0090x0080	90 x 3"
106/0040x0025	40 x 1"	106/0090x0100	90 x 4"
106/0040x0032	40 x 1 1/4"	106/0110x0100	110 x 4"
106/0040x0040	40 x 1 1/2"		

ELBOW FEMALE

PN 16



ITEM CODE	METRIC mm x BSP	ITEM CODE	METRIC mm x BSP	ITEM CODE	METRIC mm x BSP
107/0020x0015	20 x 1/2"	107/0040x0020	40 x 3/4"	107/0063x0065	63 x 2 1/2"
107/0020x0020	20 x 3/4"	107/0040x0025	40 x 1"	107/0075x0050	75 x 2"
107/0025x0015	25 x 1/2"	107/0040x0032	40 x 1 1/4"	107/0075x0065	75 x 2 1/2"
107/0025x0020	25 x 3/4"	107/0040x0040	40 x 1 1/2"	107/0075x0080	75 x 3"
107/0025x0025	25 x 1"	107/0050x0032	50 x 1 1/4"	107/0090x0080	90 x 3"
107/0032x0015	32 x 1/2"	107/0050x0040	50 x 1 1/2"	107/0090x0100	90 x 4"
107/0032x0020	32 x 3/4"	107/0050x0050	50 x 2"	107/0110x0080	110 x 3"
107/0032x0025	32 x 1"	107/0063x0040	63 x 1 1/2"	107/0110x0100	110 x 4"
107/0032x0032	32 x 1 1/4"	107/0063x0050	63 x 2"		

TEE

PN 16



ITEM CODE	METRIC mm
108/0020	20
108/0025	25
108/0032	32
108/0040	40
108/0050	50
108/0063	63
108/0075	75
108/0090	90
108/0110	110

TEE MALE

PN 16



ITEM CODE	METRIC mm x BSP	ITEM CODE	METRIC mm x BSP
109/0020x0015	20 x 1/2"	109/0050x0032	50 x 1 1/4"
109/0020x0020	20 x 3/4"	109/0050x0040	50 x 1 1/2"
109/0025x0015	25 x 1/2"	109/0050x0050	50 x 2"
109/0025x0020	25 x 3/4"	109/0063x0040	63 x 1 1/2"
109/0025x0025	25 x 1"	109/0063x0050	63 x 2"
109/0032x0015	32 x 1/2"	109/0063x0065	63 x 2 1/2"
109/0032x0020	32 x 3/4"	109/0075x0065	75 x 2 1/2"
109/0032x0025	32 x 1"	109/0075x0080	75 x 3"
109/0032x0032	32 x 1 1/4"	109/0090x0080	90 x 3"
109/0040x0025	40 x 1"	109/0090x0100	90 x 4"
109/0040x0032	40 x 1 1/4"	109/0110x0100	110 x 4"
109/0040x0040	40 x 1 1/2"		

TEE FEMALE

PN 16



ITEM CODE	METRIC mm x BSP	ITEM CODE	METRIC mm x BSP	ITEM CODE	METRIC mm x BSP
110/0020x0015	20 x 1/2"	110/0040x0032	40 x 1 1/4"	110/0075x0050	75 x 2"
110/0020x0020	20 x 3/4"	110/0040x0040	40 x 1 1/2"	110/0075x0065	75 x 2 1/2"
110/0025x0015	25 x 1/2"	110/0050x0015	50 x 1/2"	110/0075x0080	75 x 3"
110/0025x0020	25 x 3/4"	110/0050x0032	50 x 1 1/4"	110/0090x0065	90 x 2 1/2"
110/0025x0025	25 x 1"	110/0050x0040	50 x 1 1/2"	110/0090x0080	90 x 3"
110/0032x0015	32 x 1/2"	110/0050x0050	50 x 2"	110/0090x0100	90 x 4"
110/0032x0020	32 x 3/4"	110/0063x0032	63 x 1 1/4"	110/0110x0080	110 x 3"
110/0032x0025	32 x 1"	110/0063x0040	63 x 1 1/2"	110/0110x0100	110 x 4"
110/0032x0032	32 x 1 1/4"	110/0063x0050	63 x 2"		
110/0040x0025	40 x 1"	110/0063x0065	63 x 2 1/2"		

TEE REDUCING

PN 16



ITEM CODE	METRIC mm	ITEM CODE	METRIC mm
113/0025x0020	25 × 20	113/0063x0025	63 × 25
113/0032x0020	32 × 20	113/0063x0032	63 × 32
113/0032x0025	32 × 25	113/0063x0040	63 × 40
113/0040x0025	40 × 25	113/0063x0050	63 × 50
113/0040x0032	40 × 32	113/0075x0063	75 × 63
113/0050x0025	50 × 25	113/0090x0063	90 × 63
113/0050x0032	50 × 32	113/0090x0075	90 × 75
113/0050x0040	50 × 40	113/0110x0090	110 × 90

END CAP

PN 16



ITEM CODE	METRIC mm
104/0020	20
104/0025	25
104/0032	32
104/0040	40
104/0050	50
104/0063	63
104/0075	75
104/0090	90
104/0110	110

COUPLING

PN 16



ITEM CODE	METRIC mm
100/0020	20
100/0025	25
100/0032	32
100/0040	40
100/0050	50
100/0063	63
100/0075	75
100/0090	90
100/0110	110

COUPLING REDUCING

PN 16



ITEM CODE	METRIC mm	ITEM CODE	METRIC mm
101/0025x0020	25 × 20	101/0063x0032	63 × 32
101/0032x0020	32 × 20	101/0063x0040	63 × 40
101/0032x0025	32 × 25	101/0063x0050	63 × 50
101/0040x0025	40 × 25	101/0075x0050	75 × 50
101/0040x0032	40 × 32	101/0075x0063	75 × 63
101/0050x0025	50 × 25	101/0090x0063	90 × 63
101/0050x0032	50 × 32	101/0090x0075	90 × 75
101/0050x0040	50 × 40	101/0110x0090	110 × 90
101/0063x0025	63 × 25		

ADAPTOR MALE

PN 16



ITEM CODE	METRIC mm x BSP	ITEM CODE	METRIC mm x BSP	ITEM CODE	METRIC mm x BSP
102/0020x0015	20 x 1/2"	102/0040x0032	40 x 1 1/4"	102/0075x0050	75 x 2"
102/0020x0020	20 x 3/4"	102/0040x0040	40 x 1 1/2"	102/0075x0065	75 x 2 1/2"
102/0020x0025	20 x 1"	102/0040x0050	40 x 2"	102/0075x0080	75 x 3"
102/0025x0015	25 x 1/2"	102/0050x0025	50 x 1"	102/0090x0050	90 x 2"
102/0025x0020	25 x 3/4"	102/0050x0032	50 x 1 1/4"	102/0090x0065	90 x 2 1/2"
102/0025x0025	25 x 1"	102/0050x0040	50 x 1 1/2"	102/0090x0080	90 x 3"
102/0032x0015	32 x 1/2"	102/0050x0050	50 x 2"	102/0090x0100	90 x 4"
102/0032x0020	32 x 3/4"	102/0063x0032	63 x 1 1/4"	102/0110x0050	110 x 2"
102/0032x0025	32 x 1"	102/0063x0040	63 x 1 1/2"	102/0110x0080	110 x 3"
102/0032x0032	32 x 1 1/4"	102/0063x0050	63 x 2"	102/0110x0100	110 x 4"
102/0040x0025	40 x 1"	102/0063x0065	63 x 2 1/2"		

ADAPTOR FEMALE

PN 16



ITEM CODE	METRIC mm x BSP	ITEM CODE	METRIC mm x BSP	ITEM CODE	METRIC mm x BSP
103/0020x0015	20 x 1/2"	103/0040x0025	40 x 1"	103/0075x0050	75 x 2"
103/0020x0020	20 x 3/4"	103/0040x0032	40 x 1 1/4"	103/0075x0065	75 x 2 1/2"
103/0020x0025	20 x 1"	103/0040x0040	40 x 1 1/2"	103/0075x0080	75 x 3"
103/0025x0015	25 x 1/2"	103/0050x0032	50 x 1 1/4"	103/0090x0050	90 x 2"
103/0025x0020	25 x 3/4"	103/0050x0040	50 x 1 1/2"	103/0090x0065	90 x 2 1/2"
103/0025x0025	25 x 1"	103/0050x0050	50 x 2"	103/0090x0080	90 x 3"
103/0032x0015	32 x 1/2"	103/0063x0032	63 x 1 1/4"	103/0090x0100	90 x 4"
103/0032x0020	32 x 3/4"	103/0063x0040	63 x 1 1/2"	103/0110x0080	110 x 3"
103/0032x0025	32 x 1"	103/0063x0050	63 x 2"	103/0110x0100	110 x 4"
103/0032x0032	32 x 1 1/4"	103/0063x0065	63 x 2 1/2"		

2.2 Fittings mecanizados para termofusión

Reducción concéntrica – Norma DIN 16963

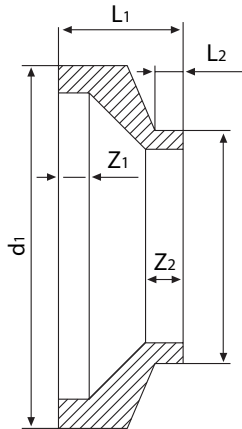

d_1 (mm)	d_2 (mm)	L_1 (mm)	L_2 (mm)	Z_1 (mm)	Z_2 (mm)
63	32 a 50	60	10	10	20
75	40 a 63				
90	50 a 75				
110	63 a 90				
125	63 a 110	100			
140	75 a 125				
160	90 a 140				
180	90 a 160	105	15	15	30
200	110 a 180				
225	125 a 200				
250	125 a 225				
280	140 a 250	125			
315	160 a 280				
355	180 a 315				
400	200 a 355	130	20	20	40
450	225 a 400	140			
500	250 a 450				
560	280 a 500				
630	315 a 560				
710	355 a 630	150	30	30	60
800	400 a 710				
900	450 a 800				
1000	500 a 900	195	30	30	60
1200	630 a 1000				
1400	710 a 1200				
1600	800 a 1400				
		220	30	30	60
		250	35	35	70
		300	45	45	90

Reducción excéntrica – Norma DIN 16963

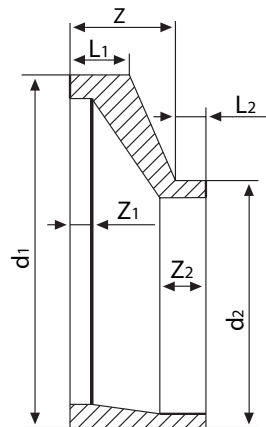

d_1 (mm)	d_2 (mm)	L_1 (mm)	L_2 (mm)	Z_1 (mm)	Z_2 (mm)	Z (mm)
63	32 a 50	40	10	10	20	60
75	40 a 63					
90	50 a 75					
110	63 a 90					
125	63 a 110	66	15	15	30	100
140	75 a 125					
160	90 a 140					
180	90 a 160					
200	110 a 180	70	20	20	40	105
225	125 a 200					
250	125 a 225					
280	140 a 250					
315	160 a 280	83	25	25	60	125
355	180 a 315					
400	200 a 355					
450	225 a 400					
500	250 a 450	86	30	30	60	130
560	280 a 500					
630	315 a 560					
710	355 a 630					
800	400 a 710	93	30	30	60	140
900	450 a 800					
1000	500 a 900					
1200	630 a 1000					
1400	710 a 1200	100	25	25	60	150
1600	800 a 1400					
		118	25	25	60	170
		146	30	30	60	220
		166	45	45	70	250
		183	45	45	90	275

2.2 Fittings mecanizados para termofusión

Stub end standard / largo – Norma DIN16963/4

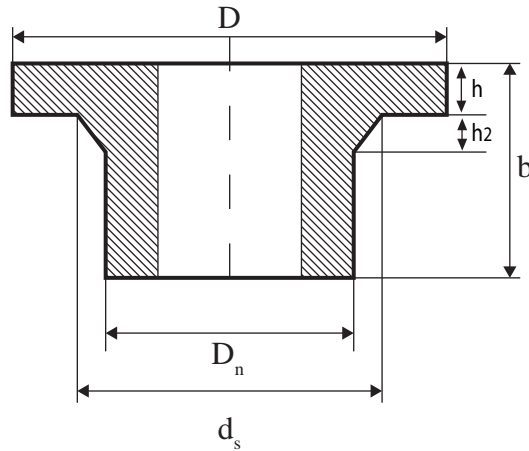

Dn (mm)	Df. (pulg.)	D (mm)	ds (mm)	h2 (mm)	h						b													
					6	8	10	12,5	16	20	6		8		10		12,5		16		20			
											Std	Lrg	Std	Lrg	Std	Lrg	Std	Lrg	Std	Lrg	Std	Lrg		
32	1	68	40	13	10	10	10	10	10	12	50		50		50		50		50		50		50	
40	1 1/4	78	50	15	11	11	11	12	12	12	50		50		50		50		50		50		50	
50	1 1/2	80	61	15	12	12	12	19	19	19	50	85	50	85	50	85	50	85	50	85	50	85	50	85
63	2	102	75	20	14	14	14	21	21	21	50	95	50	95	50	95	50	95	50	95	50	95	50	95
75	2 1/2	122	89	20	16	16	16	23	23	23	50	125	50	125	50	125	50	125	50	125	50	125	50	125
90	3	138	105	20	17	17	17	24	24	24	80	140	80	140	80	140	80	140	80	140	80	140	80	140
110	4	158	125	25	18	18	18	26	26	26	80	160	80	160	80	160	80	160	80	160	80	160	80	160
125	5	158	132	20	18	25	25	26	26	26	80	170	80	170	80	170	80	170	80	170	80	170	80	170
140	5	188	155	28	18	25	25	26	26	26	80	200	80	200	80	200	80	200	80	200	80	200	80	200
160	6	212	175	28	18	25	25	28	38	40	80	200	80	200	80	200	80	200	100	200	100	200	100	200
180	6	212	185	30	20	30	30	34	42	50	80	200	80	200	80	200	80	200	100	200	100	200	100	200
200	8	268	232	40	24	32	32	36	52	52	100	200	100	200	100	200	100	200	120	200	120	200	120	200
225	8	268	235	30	24	32	32	36	52	52	100	200	100	200	100	200	100	200	120	200	120	200	120	200
250	10	320	285	40	25	35	35	40	52	65	100	200	100	200	100	200	100	200	120	200	120	200	120	200
280	10	320	291	30	25	35	35	40	65	65	100	200	100	200	100	200	100	200	120	200	120	200	140	200
315	12	370	335	40	25	35	35	40	65	65	100	200	100	200	100	200	100	200	120	200	140	200	140	200
355	14	430	373	40	30	40	40	42	65	65	120	200	120	200	130	200	140	200	140	200	150	200	150	200
400	16	482	427	45	33	46	46	48	65	65	120	200	120	200	130	200	140	200	140	200	150	200	150	200
450		585	514																					
450*	18	540	494	60	46	60	60	65	70	70	120	220	140	220	140	220	140	220	150	220	160	220	160	220
500	20	585	530	50	46	60	60	65	70	70	120	225	140	225	140	225	140	225	150	225	160	225	160	225
560		685	615																					
560*	22	650	588	60	50	60	60	65	75	75	120	260	140	260	140	260	150	260	160	260	180	260	180	260
630	24	685	642	40	50	60	60	65	80	85	120	260	140	260	140	260	150	260	160	260	180	260	180	260
710	28	800	737	50	50	65	65	70	80	90	120	300	140	300	140	300	160	300	180	300	200	300	200	300
760	30	876	771	50	50	65	65	70	80	90	120	300	140	300	160	300	160	300	180	300	200	300	200	300
800	32	905	840	50	52	75	75	75	80	90	140	300	160	300	160	300	180	300	200	300	200	300	200	300
900	36	1005	944	50	55	75	75	75	80	95	140	350	160	350	160	350	180	350	200	350	200	350	200	350
1000	40	1110	1047	70	60	75	75	75	90	95	160	350	180	350	180	350	200	350	200	350	200	350	220	350
1100	44	1260	1180	70	65	75	75	75	95	100	180	400	180	400	200	400	220	400	240	400	240	400	240	400
1200	48	1330	1245	70	65	75	75	75	95	100	180	400	180	400	200	400	220	400	240	400	240	400	240	400
1400	54	1505	1445	90	70	75	75	75	95	100	180	450	200	450	200	450	220	450	240	450	240	450	250	450
1600	66	1850	1640	90	70	75	75	75	100	100	200	500	200	500	200	500	240	500	250	500	250	500	250	500

* Existe diferencia según el tipo de flange (*ANSI)

Stub end standard / largo para válvula mariposa

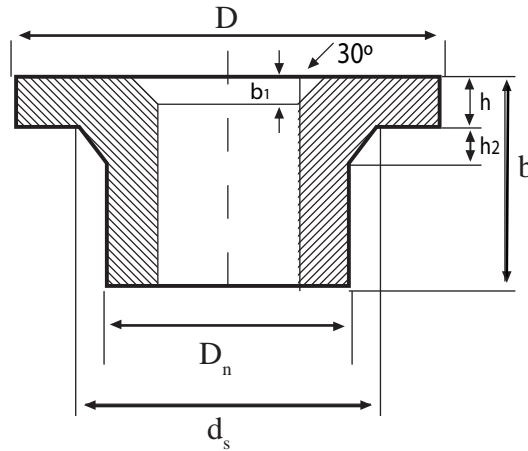

Dn (mm)	Df. (pulg)	D (mm)	ds (mm)	h2 (mm)	h						b										b1 (mm)				
					6	8	10	12,5	16	20	6		8		10		12,5		16			20			
											Std	Lrg	Std	Lrg	Std	Lrg	Std	Lrg	Std	Lrg	Std	Lrg	Std	Lrg	
75	2 1/2	122	89	20	16	16	16	23	23	23	50	125	50	125	50	125	50	125	50	125	50	125	50	125	10
90	3	138	105	20	17	17	17	24	24	24	80	140	80	140	80	140	80	140	80	140	80	140	80	140	10
110	4	158	125	25	18	18	18	26	26	26	80	160	80	160	80	160	80	160	80	160	80	160	80	160	15
125	5	158	132	20	18	25	25	26	26	26	80	170	80	170	80	170	80	170	80	170	80	170	80	170	15
140	5	188	155	28	18	25	25	26	26	26	80	200	80	200	80	200	80	200	80	200	80	200	80	200	15
160	6	212	175	28	18	25	25	28	38	40	80	200	80	200	80	200	80	200	100	200	100	200	100	200	15
180	6	212	185	30	20	30	30	34	42	50	80	200	80	200	80	200	80	200	100	200	100	200	100	200	15
200	8	268	232	40	24	32	32	36	52	52	100	200	100	200	100	200	100	200	120	200	120	200	120	200	15
225	8	268	235	30	24	32	32	36	52	52	100	200	100	200	100	200	100	200	120	200	120	200	120	200	15
250	10	320	285	40	25	35	35	40	52	65	100	200	100	200	100	200	100	200	120	200	120	200	120	200	15
280	10	320	291	30	25	35	35	40	65	65	100	200	100	200	100	200	100	200	120	200	120	200	140	200	15
315	12	370	335	40	25	35	35	40	65	65	100	200	100	200	100	200	100	200	120	200	140	200	140	200	20
355	14	430	373	40	30	40	40	42	65	65	120	200	120	200	130	200	140	200	140	200	150	200	150	200	20
400	16	482	427	45	33	46	46	48	65	65	120	200	120	200	130	200	140	200	140	200	150	200	150	200	20
450	18	585	514	60	46	60	60	65	70	70	120	220	140	220	140	220	140	220	150	220	160	220	160	220	20
500	20	585	494	50	46	60	60	65	70	70	120	225	140	225	140	225	140	225	150	225	160	225	160	225	20
560	22	685	615	60	50	60	60	65	75	75	120	260	140	260	140	260	150	260	160	260	180	260	180	260	20
630	24	685	588	40	50	60	60	65	80	85	120	260	140	260	140	260	150	260	160	260	180	260	180	260	20
710	28	800	737	50	50	65	65	70	80	90	120	300	140	300	140	300	150	300	180	300	200	300	200	300	20
760	30	876	771	50	50	65	65	70	80	90	120	300	140	300	160	300	160	300	180	300	200	300	200	300	20
800	32	905	840	50	52	75	75	75	80	90	140	300	160	300	160	300	180	300	200	300	200	300	200	300	20
900	36	1005	944	50	55	75	75	75	80	95	140	350	160	350	160	350	180	350	200	350	200	350	200	350	20
1000	40	1110	1047	70	60	75	75	75	90	95	160	350	180	350	180	350	200	350	200	350	220	350	220	350	20
1100	44	1260	1180	70	65	75	75	75	95	100	180	400	180	400	200	400	220	400	240	400	240	400	240	400	20
1200	48	1330	1245	70	65	75	75	75	95	100	180	400	180	400	200	400	220	400	240	400	240	400	240	400	20
1400	54	1505	1445	90	70	75	75	75	95	100	180	450	200	450	200	450	220	450	240	450	250	450	250	450	20
1600	66	1850	1640	90	70	75	75	75	100	100	200	500	200	500	200	500	240	500	250	500	250	500	250	500	20

2.2 Fittings mecanizados para termofusión

Stub end cara completa

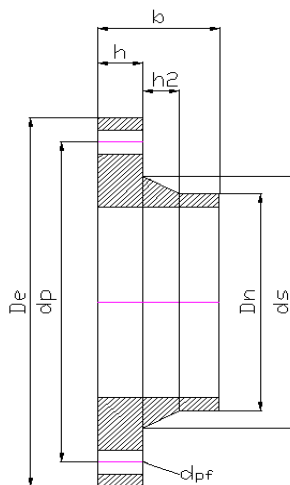

DIN 2673 PN 10

Dn mm	D PN10	Df. Pulg.	ds mm	h2 mm	b / PN					h / PN					FLANGE DIN 2673 PN10			
					6	8	10	12,5	16	6	8	10	12,5	16	De mm	dp.	dpf.	N°
63	50	2	75	20	50	50	50	60	60	16	16	16	24	24	165	125	18	4
75	65	2 1/2	89	20	50	50	50	60	60	18	18	18	26	26	185	145	18	4
90	80	3	105	20	80	80	80	80	80	20	20	20	28	28	200	160	18	8
110	100	4	125	25	80	80	80	80	80	21	21	21	30	30	220	180	18	8
125		5	132	20	80	80	80	80	90	21	29	29	32	38	250	210	18	8
140		5	155	28	80	80	80	80	90	21	29	29	32	38	250	210	18	8
160	150	6	175	28	80	80	80	80	100	21	29	29	32	52	285	240	22	8
180		6	185	30	80	80	80	100	120	23	35	35	39	58	285	240	22	8
200	200	8	232	40	100	100	100	100	120	28	37	37	41	60	340	295	22	8
225		8	235	30	100	100	100	100	120	28	37	37	41	60	340	295	22	8
250	250	10	285	40	100	100	100	100	140	29	40	40	46	75	395	350	22	12
280		10	291	30	100	100	100	100	140	29	40	40	46	75	395	350	22	12
315	300	12	335	40	100	120	120	120	150	29	40	40	46	75	445	400	22	12
355	350	14	373	40	120	120	130	140	160	35	46	46	48	75	505	460	22	16
400	400	16	427	45	120	120	130	140	180	38	53	53	55	75	565	515	26	16
450	450	18	514	60	140	160	160	180	200	53	69	69	75	81	615	565	26	20
*			494		140	160	160	180	200									
500	500	20	530	50	140	160	160	180	200	53	69	69	75	81	670	620	28	20
560		22	615	60	140	160	160	180	200	58	69	69	75	86	780	725	30	20
*			588		140	160	160	180	200									
630	600	24	642	40	140	160	160	200	200	58	69	69	75	92	780	725	30	24

* Existe diferencia según el tipo de flange (*ANSI)

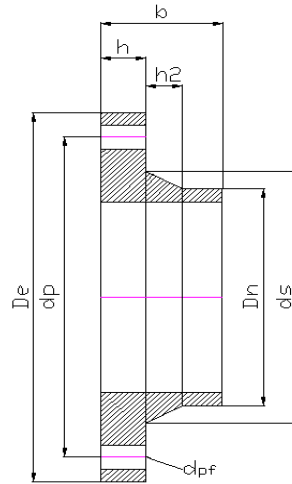

ANSI B16.5 # 150

Dn mm	D PN10	Df. Pulg.	ds mm	h2 mm	b / PN					h / PN					FLANGE ANSIB16,5 #150			
					6	8	10	12,5	16	6	8	10	12,5	16	De mm	dp.	dpf.	Nº
63	50	2	75	20	50	50	50	60	60	16	16	16	24	24	152	121	19	4
75	65	2 1/2	89	20	50	50	50	60	60	18	18	18	26	26	178	140	19	4
90	80	3	105	20	80	80	80	80	80	20	20	20	28	28	191	152	19	8
110	100	4	125	25	80	80	80	80	80	21	21	21	30	30	229	191	19	8
125		5	132	20	80	80	80	80	90	21	29	29	32	38	254	216	22	8
140		5	155	28	80	80	80	80	90	21	29	29	32	38	254	216	22	8
160	150	6	175	28	80	80	80	80	100	21	29	29	32	52	279	241	22	8
180		6	185	30	80	80	80	100	120	23	35	35	39	58	279	241	22	8
200	200	8	232	40	100	100	100	100	120	28	37	37	41	60	343	298	22	8
225		8	235	30	100	100	100	100	120	28	37	37	41	60	343	298	22	8
250	250	10	285	40	100	100	100	100	140	29	40	40	46	75	406	362	25	12
280		10	291	30	100	100	100	100	140	29	40	40	46	75	406	362	25	12
315	300	12	335	40	100	120	120	120	150	29	40	40	46	75	483	432	25	12
355	350	14	373	40	120	120	130	140	160	35	46	46	48	75	533	476	29	16
400	400	16	427	45	120	120	130	140	180	38	53	53	55	75	597	540	29	16
450	450	18	514	60	140	160	160	180	200	53	69	69	75	81				20
*			494		140	160	160	180	200						635	578	32	
500	500	20	530	50	140	160	160	180	200	53	69	69	75	81	699	635	32	20
560		22	615	60	140	160	160	180	200	58	69	69	75	86				20
*			588		140	160	160	180	200						749	692	35	
630	600	24	642	40	140	160	160	200	200	58	69	69	75	92	813	749	35	24

* Existe diferencia según el tipo de flange (*ANSI)

2.2 Fittings mecanizados para termofusión

Cap end – Norma ISO 4427

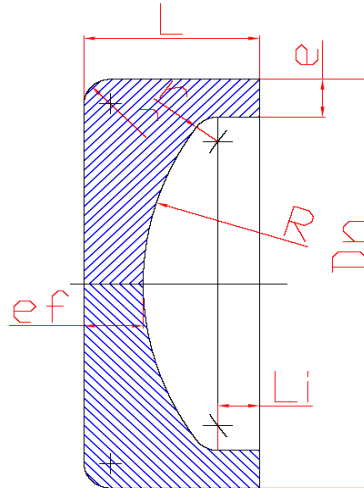

Dn (mm)	68				10				10			
	L	Li	ef	R	L	Li	ef	R	L	Li	ef	R
32	60	52,5	5	37	60	52,5	5	37	60	52,5	5	37
40	60	51,5	5	45,0	60	51,5	5	45	60	51,5	5	45
50	60	50,2	5	55	60	50,2	5	55	60	49,5	6	56
63	60	48,5	5	68	60	48,6	5	68	60	7,2	7	70
75	60	47,2	5	80	60	46,2	6	81	60	45	8	84
90	80	64,5	6	97	80	64,6	6	97	80	61,5	10	101
110	80	61,2	7	118	80	60,3	8	119	80	57,5	12	123
125	80	58,5	8	134	80	57,7	9	135	80	54,9	13	140
140	80	55,8	9	150	80	55	10	151	80	52,4	14	157
160	80	52,7	10	172	80	51,9	11	173	80	48,5	16	179
180	80	48,5	12	193	80	48,8	12	194	80	44,6	18	202
200	100	65,4	13	215	100	64,6	14	216	100	60,7	20	224
225	100	61,7	14	242	100	61	15	243	100	55,3	23	252
250	100	57,0	16	269	100	56,3	17	270	100	50,8	25	281
280	120	71,7	18	301	120	71	19	302	120	64,9	28	314
315	120	66,0	20	339	120	65,4	21	340	120	57,6	32	354
355	150	99,6	22	382	160	98	24	383	160	89,6	36	399
400	150	81,7	25	430	160	80,2	27	432	160	71,3	40	449
450	150	73,3	28	486	160	71,9	30	486	160	61,5	45	505
500	150	64,9	31	538	160	63,5	33	540	160	51,6	50	561
560	150	54,5	35	602	160	53,2	37	605	160	39,9	56	629
630	150	42,9	39	678	160	41,7	41	681	160	26,1	63	708

Transición de espesor – Norma ISO 4427

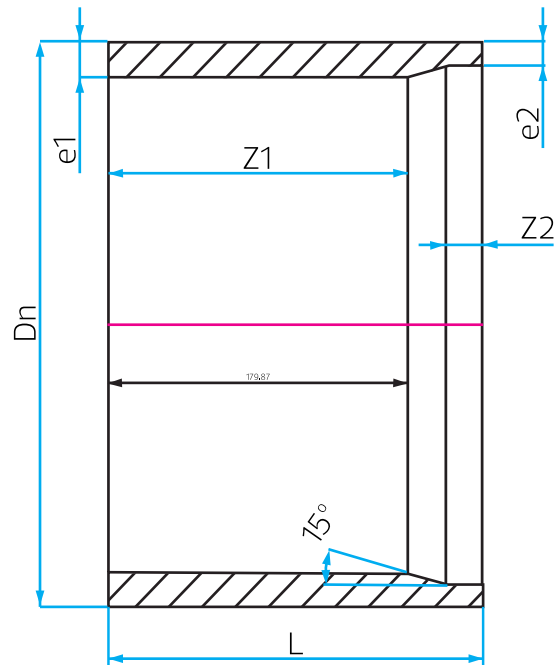

Diámetro Dn (mm)	Largo L (mm)	Sección recta Z (mm)
20 a 110	80	Z = 110%e ₁
125 a 160	120	
180 a 280	150	
315 a 355	180	
400 a 500	200	
560 a 630	250	Z = 115%e ₁
710	260	
800 a 1000	300	
1200	350	
> 1200	400	

e₁ es el espesor mayor

Codo 30° (± 2°) – Norma DIN 16963

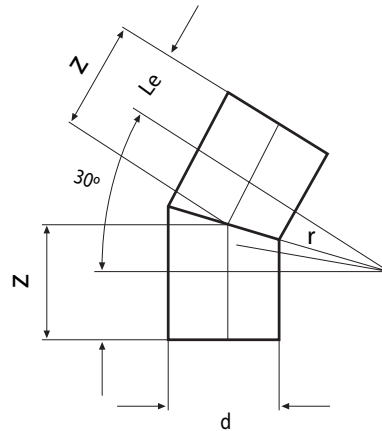

Diámetro tubo d (mm)	Diámetro tubo d (pulg)	Sección recta Le (mm)	Radio (=1,5 d) r (mm)	Avance Z (mm)
110	4	150	165	194
125	5		188	200
140	5 1/2		210	206
160	6		240	214
180	7		270	222
200	8		300	230
225	9		338	241
250	10	250	375	350
280	11		420	362
315	12		473	428
355	14	300	533	443
400	16		600	461
450	18		675	481
500	20	350	750	551
560	22		840	575
630	24		945	603
710	28		1065	636
800	32	400	1200	672
900	36		1350	762
1000	40		1500	802
1200	48		1800	882
1400	54		2100	963
1600	64		2400	1043

2.1 Fittings mitrados para termofusión

Codo 45° (± 2°) – Norma DIN 16963

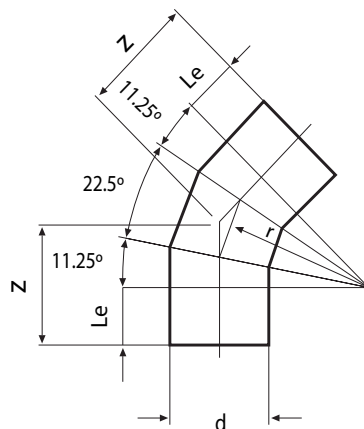

Diámetro tubo d (mm)	Diámetro tubo d (pulg)	Sección recta Le (mm)	Radio (=1,5 d) r (mm)	Avance – 45° Z (mm)
110	4	150	165	218
125	5		188	228
140	5 1/2		210	237
160	6		240	249
180	7		270	262
200	8		300	274
225	9		338	290
250	10	250	375	412
280	11		420	424
315	12	300	473	298
355	14		533	520
400	16		600	548
450	18		675	580
500	20		750	665
560	22	350	840	698
630	24		945	741
710	28		1065	792
800	32	400	1200	847
900	36		1350	960
1000	40		1500	1022
1200	48		1800	1146
1400	54		2100	1270
1600	64		2400	1394

Codo 60° (± 2°) – Norma DIN 16963

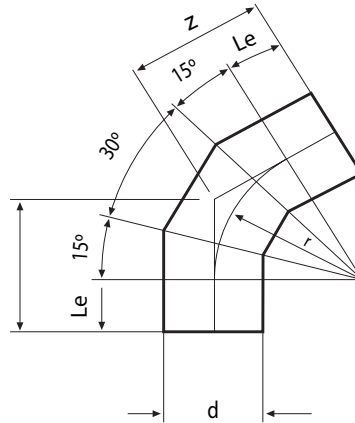

Diámetro tubo d (mm)	Diámetro tubo d (pulg)	Sección recta Le (mm)	Radio (=1,5 d) r (mm)	Avance – 60° Z (mm)
110	4	150	165	245
125	5		188	258
140	5 1/2		210	271
160	6		240	288
180	7		270	305
200	8		300	323
225	9		338	345
250	10	250	375	466
280	11		420	492
315	12	300	473	576
355	14		533	608
400	16		600	646
450	18		675	689
500	20	350	750	783
560	22		840	835
630	24		945	896
710	28		1065	965
800	32		1200	1043
900	36	400	1350	1179
1000	40		1500	1266
1200	48		1800	1439
1400	54		2100	1612
1600	64		2400	1786

2.1 Fittings mitrados para termofusión

Codo 90° (± 2°) – Norma DIN 16963

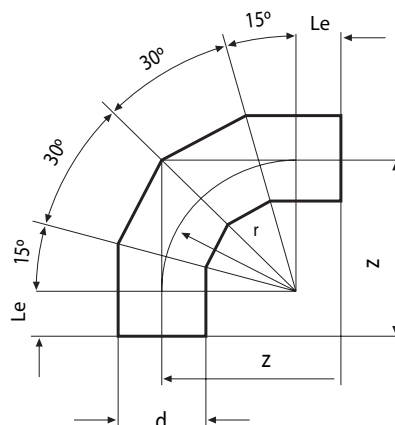

Diámetro tubo d (mm)	Diámetro tubo d (pulg)	Sección recta Le (mm)	Radio (=1,5 d) r (mm)	Avance Z (mm)
110	4	150	165	315
125	5		188	338
140	5 1/2		210	360
160	6		240	390
180	7		270	420
200	8		300	450
225	9		338	488
250	10	250	375	625
280	11		420	670
315	12		473	773
355	14	300	533	833
400	16		600	900
450	18		675	975
500	20	350	750	1100
560	22		840	1190
630	24		945	1295
710	28		1065	1415
800	32		1200	1550
900	36	400	1350	1750
1000	40		1500	1900
1200	48		1800	2200
1400	54		2100	2500
1600	64		2400	2800

Tee 90° (± 2°) – Norma DIN 16963

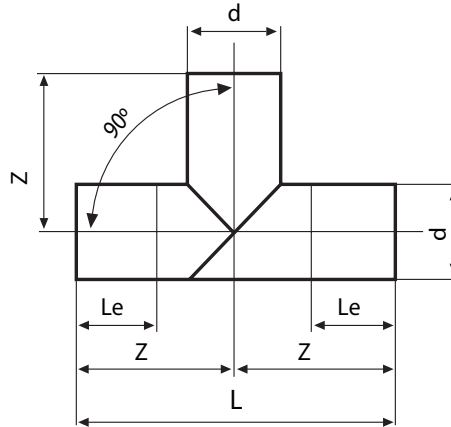

Diámetro o tubo d (mm)	Diámetro o tubo d (pulg)	Sección recta Le (mm)	Avance Z (mm)	Largo L (mm)
110	4	150	205	410
125	5		215	430
140	5 1/2		220	440
160	6		230	460
180	7		240	480
200	8		250	500
225	9		265	530
250	10	250	375	750
280	11		390	780
315	12	300	460	920
355	14		480	960
400	16		500	1000
450	18		525	1050
500	20	350	600	1200
560	22		630	1260
630	24		665	1330
710	28		706	1410
800	32	400	750	1500
900	36		850	1700
1000	40		900	1800
1200	48		1000	2000
1400	54		1100	2200
1600	64		1200	2400

2.1 Fittings mitrados para termofusión

Tee 60° (± 2°) – Norma DIN 16963

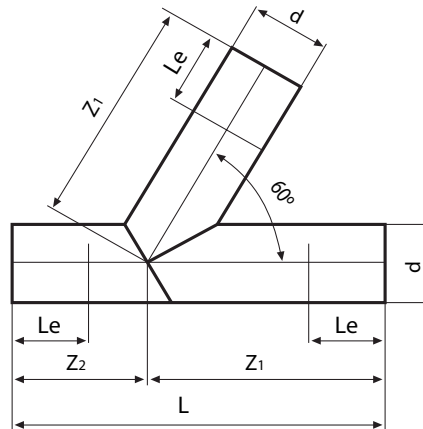

Diámetro tubo d (mm)	Diámetro tubo d (pulg)	Sección recta Le (mm)	Avance 1 Z ₁₂ (mm)	Avance 2 Z (mm)
110	4	150	325	175
125	5		355	190
140	5 1/2		375	206
160	6		412	230
180	7		450	250
200	8		487	272
225	9		530	300
250	10	250	580	325
280	11		630	365
315	12		690	400
355	14	300	730	425
400	16		800	450
450	18		850	475
500	20	350	900	500
560	22		950	530
630	24		1000	545
710	28		1090	580
800	32		1180	630
900	36	400	1320	670
1000	40		1500	710
1200	48		1800	860
1400	54		2200	1000
1600	64		2500	1000

Tee 45° (± 2°)

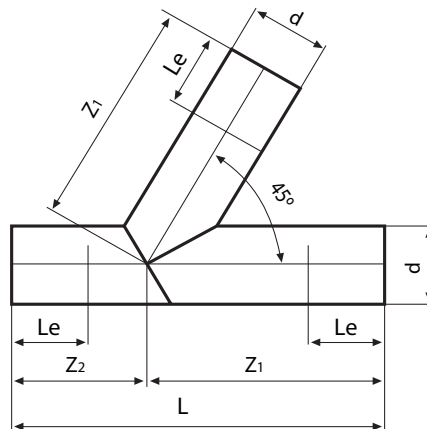

Diámetro tubo d (mm)	Diámetro tubo d (pulg)	Sección recta Le (mm)	Avance 1 Z ₁₂ (mm)	Avance 2 Z (mm)
110	4	150	475	175
125	5		475	190
140	5 1/2		475	206
160	6		475	230
180	7		875	250
200	8		875	272
225	9		875	300
250	10	250	875	325
280	11		900	365
315	12		900	400
355	14	300	900	425
400	16		900	450
450	18		1100	475
500	20	350	1100	500
560	22		1200	530
630	24		1200	545
710	28		1500	580
800	32		1500	630
900	36	400	2000	670
1000	40		2000	710
1200	48		2000	860
1400	54		2200	1000
1600	64		2500	1000

2.1 Fittings mitrados para termofusión

Tee 90° con reducción

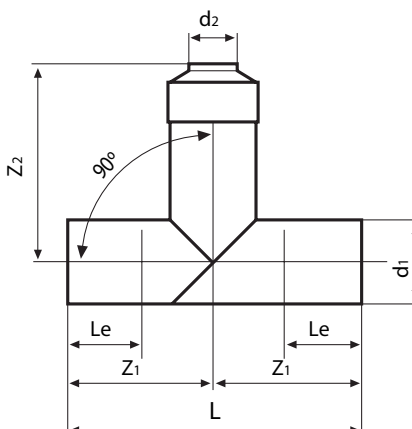

Diámetro tubo d_1 (mm)	Diámetro tubo d_1 (pulg)	Diámetro reducción d_2 (mm)	Sección recta Le (mm)	Avance 1 Z_1 (mm)	Avance 2 Z_2 (mm)
110	4	63 a 90	150	205	263
125	5	63 a 110		215	313
140	5 1/2	75 a 125		220	318
160	6	90 a 140		230	328
180	7	90 a 160		240	341
200	8	110 a 180		250	351
225	9	125 a 200		265	366
250	10	125 a 225	250	375	476
280	11	140 a 250		390	491
315	12	160 a 280	300	460	579
355	14	180 a 315		480	599
400	16	200 a 355		500	624
450	18	225 a 400		525	649
500	20	250 a 450	350	600	722
560	22	280 a 500		630	752
630	24	315 a 560		665	797
710	28	355 a 630		705	847
800	32	400 a 710	400	750	912
900	36	450 a 800		850	1035
1000	40	500 a 900		900	1085
1200	48	630 a 1000		1000	1210
1400	54	710 a 1200		1100	1340
1600	64	800 a 1400		1200	1490

El sistema BRUNO® ofrece una línea integral de productos para unir mecánicamente tuberías HDPE rápido, fácil, económico y seguro.

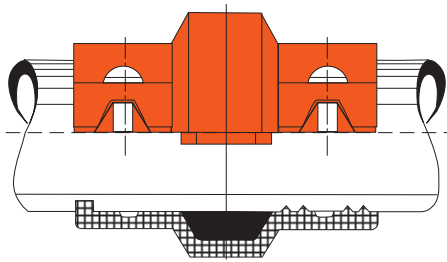

■ ACOPLAMIENTO ESTILO 995



ESPECIFICACIÓN DE MATERIALES

Carcasa: Fundición Nodular ASTM A-536, Grado 65.45.12

Terminación: Pintura electrostática

Norma: ASTM B-117 (contra corrosión), Esmalte Naranja.

Opcional: Electrolgalvanizado.

Empaquetadura: EPDM Grado "E"

Opcional: Nitrilo Grado "T".

Pernos y tuercas: ASTM A-183 - Cuello ovalado electrozincados.

Opcional: Acero Inoxidable 304 o 316.

■ ACOPLAMIENTO ESTILO 995 EN MILIMETROS

Los acoplamientos BRUNO® Estilo 995 cuentan con hileras de dientes de sujeción integrales a cada lado de la carcasa, los cuales muerden el tubo de HDPE alrededor de toda la circunferencia y ancho de la carcasa.

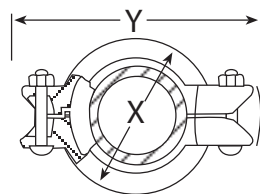
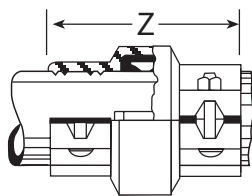

- Conexión rápida efectuada fácilmente con pernos.
- La tubería se desmonta y se rota fácilmente.
- El peso y el trabajo de unión son menores en comparación con la tubería con Flanges.
- NO hay necesidad de fundir los tubos.
- La instalación puede realizarse en condiciones adversas de clima.
- Cada junta forma una unión.
- No requiere de equipos especializados ni máquinas para su instalación.

Tubería HDPE		Dimensiones mm.			Pernos y Tuercas		Peso Aprox. Kg
DN mm.	Deformación max. mm.	X mm.	Y mm.	Z mm.	Cant.	Dimens. Pulg.	
40	40,4	60	120	60	2	3/8 x 1 7/8	1,2
50	50,5	75	130	73	2	3/8 x 1 7/8	1,5
63	64,0	95,5	140,5	92	2	1/2 x 2 3/4	1,9
75	76,0	64	155	98	2	1/2 x 2 3/4	2,2
90	90,9	118	166	116	4	1/2 x 2 3/4	3,8
110	111,0	145	193	146	4	1/2 x 2 3/4	5,5
125	126,5	170	235	150	4	5/8 x 3 1/4	6,3
140	141,3	176	240	149	4	5/8 x 3 1/4	6,5
160	161,5	195	259	149	4	5/8 x 3 1/4	7,2
180	181,8	220	310	152	4	5/8 x 3 1/4	10,2
200	201,8	240	313	152	4	5/8 x 3 1/4	10,7
225	227,1	265	336	152	4	5/8 x 3 1/4	11,2
250	252,3	293	370	165	4	3/4 x 5	18,3
280	282,6	321	397	165	4	3/4 x 5	20
315	317,9	356	432	178	4	7/8 x 5	23,4
355	358,2	413	478	195	4	7/8 x 5	35,6
400	403,6	456	564	229	4	1 x 6 1/2	46
450	453,8	516	614	241	6	7/8 x 5	52,2
500	504,0	566	665	254	6	7/8 x 5	59,8
630†							

† Para mayores diámetros consultar sobre disponibilidad y especificaciones.



■ INSTRUCCIONES DE INSTALACION PARA ACOPLAMIENTO ESTILO 995

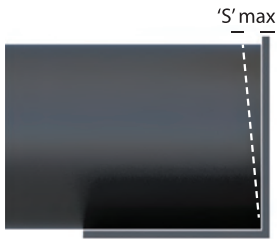

1. CORTE DE LA TUBERIA: Haga un corte en los extremos del tubo a escuadra, con "S" máximo de 1/8 pulg.(3 mm) para tamaños hasta 4 pulg. y de 5/32 pulg.(4 mm) para tamaños de 5 pulg. y superiores.

Asegúrese que los extremos del tubo estén limpios, libres de rasguños o estropeados en un área de 1 pulg. desde el extremo.

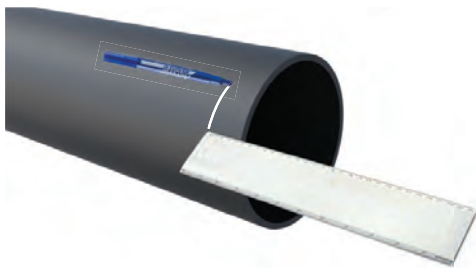

2. MARQUE EL TUBO: Con una cinta de medir y un marcador de color adecuado, marque, desde el extremo, 15/16 pulg. (24 mm) para tamaños hasta 12 pulg. y de 1 7/16 (37 mm) para tamaños mayores.

Provea de 4 marcas igualmente separadas.

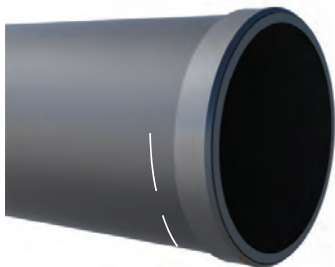

3. INSTALE LA EMPAQUETADURA: Revise la empaquetadura, para estar seguro que es la adecuada para el servicio a realizar.

Ponga la empaquetadura en el extremo de la tubería. Procure que no salga por el extremo.

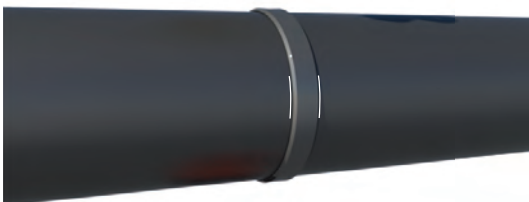

4. MONTAR: Alinee y junte los extremos de la tubería. Deslice la empaquetadura en posición centrandola entre las marcas (paso 2).

Es preferible que se topen los extremos. El espacio entre estos no debe exceder 1/4 pulg.(6-7 mm).

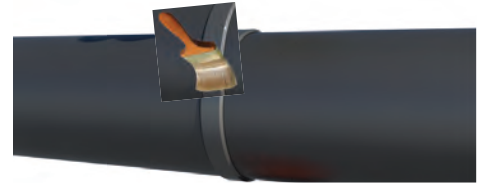

5. LUBRIQUE: Lubrique la parte exterior de la empaquetadura usando aceite de maíz, aceite de soya, glicerina, aceite de silicona o lubricante a base de silicona. NO use aceite a base de hidrocarburos, grasa o soluciones a base de jabón.

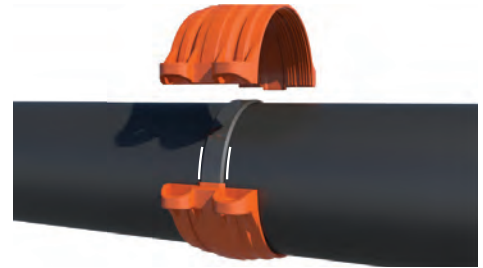

6. INSTALE EL ACOPLE: Instale los segmentos sobre la empaquetadura, asegurándose que ésta permanezca centrada sobre los extremos de la tubería. Inserte los pernos y enrosque una tuerca en cada perno. Apriete con la mano.

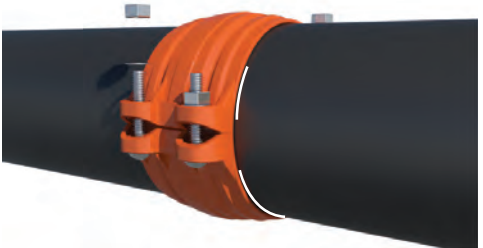

7. APRIETE LAS TUERCAS: Apriete de manera uniforme alternando ambos lados hasta obtener contacto metal con metal.

Es esencial hacerlo de manera uniforme para prevenir apretones en la empaquetadura.

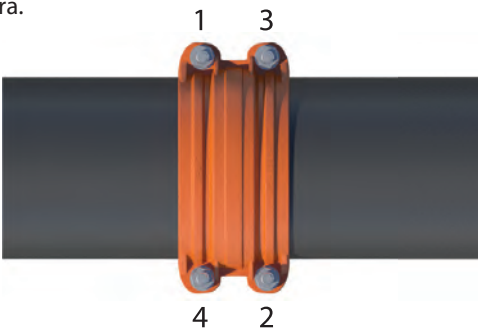

8. PATRON DE APRIETE DE TUERCAS: Alternado e uniforme.

* Los sistemas de tuberías siempre deben despresurizarse y drenarse antes de intentar desmontar y remover cualquier producto para tuberías BRUNO®.

Presión máxima de trabajo es dictada por la presión de trabajo especificada del tubo. La clasificación de los fabricantes del tubo depende del espesor, la composición y la temperatura a trabajar.

Consulte la compatibilidad de los lubricantes con el fabricante de la tubería.

Use guantes, gafas de seguridad, casco y calzado de seguridad al manipular e instalar los Acoplamiento BRUNO®.



Notas

BRUNO MR

■ ACOPLAMIENTO ESTILO 995 EN PULGADAS

Tubería HDPE		Dimensiones mm.			Pernos y Tuercas		Peso Aprox. Kg.
DN	D.EXT	X	Y	Z	Cant.	Dimens. Pulg.	
pulg.	mm.	mm.	mm.	mm.			
2	60,3	92	140	92	2	1/2x2 1/2	1,6
3	88,9	118	165	116	4	1/2x2 3/4	3,5
4	114,3	149	197	146	4	1/2x2 3/4	5,3
6	168,3	203	267	149	4	5/8x3 1/4	7,4
8	219,1	259	330	152	4	5/8x3 1/4	11,3
10	273,1	314	391	165	4	3/4x5	17,0
12	323,9	365	441	178	4	7/8x5	22,2

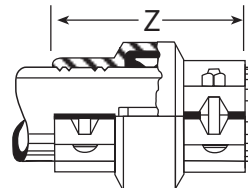
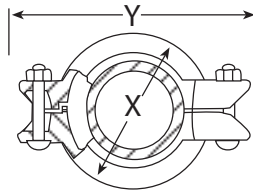

Notas

Para este diámetro de acoplamiento, consulte por especificaciones.

La presión de trabajo de los acoplamientos está determinada por presión de trabajo de la tubería.

Las indicaciones de los fabricantes de tuberías dependerán del grosor de la pared, la composición de la tubería y la temperatura.

Los acoplamientos estilo 995 BRUNO® están diseñados para utilizarse únicamente con tuberías HDPE. Estos productos no se deberían usar con otros materiales plásticos como PVC.

■ ACOPLAMIENTO DE TRANSICIÓN ESTILO 997M / 997P

Los acoplamientos BRUNO® Estilo 997 cuentan con hileras de dientes de sujeción integrales para unir el extremo de tubería HDPE, y con un diseño con cuñas para unir el extremo de cañería de acero ranurada.

El estilo 997 M, sirve para unir la transición de cañería de acero ranurada a HDPE en milímetros.

El estilo 997 P, sirve para unir la transición de cañería de acero ranurada a HDPE en pulgadas.



Cañería de Acero		Tubería HDPE D. Exterior		Dimensiones mm.			Pernos y Tuercas		Peso Kg.
DN	D.EXT	997M	997P	X	Y	Z	Cant.	Dimens. Pulg.	
pulg.	mm.	mm.	pulg.	mm.	mm.	mm.			
2	60,3	60	60,3	92	140	75	2	1/2 x 2 3/4	1,6
2 1/2	73	75	73	105	154	103	2	1/2 x 2 3/4	1,8
3	88,9	90	88,9	118	165	116	4	1/2 x 2 3/4	3,6
4	114,3	110	114,3	149	197	146	4	1/2 x 2 3/4	5,4
5	141,3	140	141,3	176	240	149	4	5/8 x 3 1/4	6,3
6	168,3	160	168,3	203	267	149	4	5/8 x 3 1/4	7,5
8	219,1	200	219,1	259	330	152	4	5/8 x 3 1/4	11,7
10	273	280	273	314	391	165	4	3/4 x 5	19,9
12	323,9	315	323,9	365	441	178	4	3/4 x 5	24,4
14	355,6	355	-	413	478	196	4	3/4 x 5	35,6
16	406,4	400	-	465	564	229	4	1 x 6 1/2	46
18	457,2	450	-	516	614	241	6	7 1/8 x 5	52,2
20	508	500	-	566	665	254	6	7 1/8 x 5	64,5

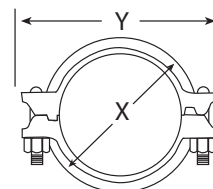
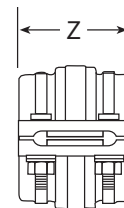

Notas

La presión de trabajo de los acoplamientos está determinada por presión de trabajo de la tubería de HDPE

Las indicaciones de los fabricantes de tuberías dependerán del grosor de la pared, la composición de la tubería y la temperatura.

Los acoplamientos estilo 997 BRUNO® están diseñados para utilizarse únicamente con tuberías HDPE. Estos productos no se deberían usar con otros materiales plásticos como PVC.

Para los acoplamientos de transición de Estilo 997, asegúrese de que las ranuras de la cañería de acero cumplan con las especificaciones de ranurado BRUNO®.